

photodetector module

PDM9125-CN data sheet

1 description

The PDM9125-CN photodetector module incorporates a 9125B 29mm diameter, fast, blue-green sensitive photomultiplier and a low consumption negative HV power supply enclosed in a cylindrical mu-metal* case. The signal output comes out directly from the photomultiplier anode and is at ground potential so that the user has the choice of operating the module in dc, pulse counting or photon counting mode. This feature makes the PDM9125-CN suitable for a very wide range of applications without compromising performance.

The module operates from a low voltage power supply which can be in the range 5V to 15V and the HV is set by choosing one of the three HV control options shown in section 9.

Variants of the PDM9125-CN, available to special order, include photomultipliers with UV transmitting windows (PDM9125W-CN) and fused silica windows (PDM9125Q-CN).



2 applications

- industrial instrumentation, especially battery powered
- research projects
- OEM prototypes
- general purpose low-level light detection

3 features

- easy to use and operate
- compact cylindrical, light-tight assembly
- integral electrostatic and magnetic shielding
- flanged mounting option available

4 photocathode spectral response

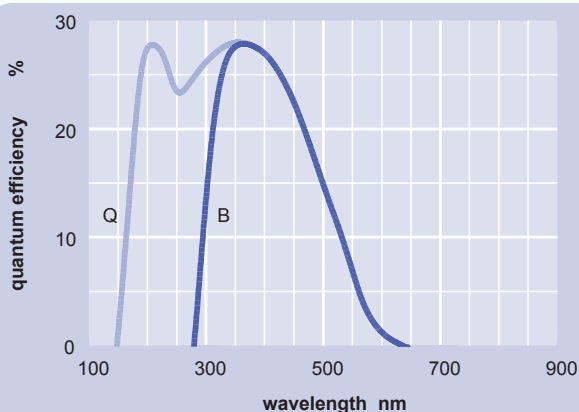

5 characteristics

	unit	min	typ	max
photocathode: bialkali				
active diameter	mm		25	
spectral response range	nm	280		630
quantum efficiency (peak)			28	
output pulse (into 50Ω)				
rise time	ns		4.5	
fwhm	ns		7.5	
output impedance (unterminated)	Ω		10M	
dark count rate @ 20°C (typ)	cps		100	
supply voltage	V	4.5		15
control voltage (1:1000)	V	0.1		2.0
supply current @ 5V:				
for anode current = 0μA	mA		1.5	
for anode current = 100μA	mA		6.5	
Supply current @ 12V:				
for anode current = 0μA	mA		1	
for anode current = 100μA	mA		5	
switch-on time (10 - 90%)	s		0.2	
switch-off time (90 - 10%)	s		25	
warm-up time	s		1	
temperature (operating)	°C	5		55
temperature (storage)	°C	-40		60
weight	g		200	

7 installation and operation

Each module is supplied with the photomultiplier test data. Wherever possible, installation should be carried out in subdued light to avoid a temporary increase in dark current during subsequent operation.

Remove the protective cap from the module before use. If necessary, the photomultiplier window can be cleaned using a lens tissue moistened with alcohol. Do not use any other solvent.

Mount the module and provide power input and signal connections. The signal lead should be terminated in 50Ω when operating with fast transients (<50 ns). Then choose one of the HV control options in section 9.

8 functional diagram

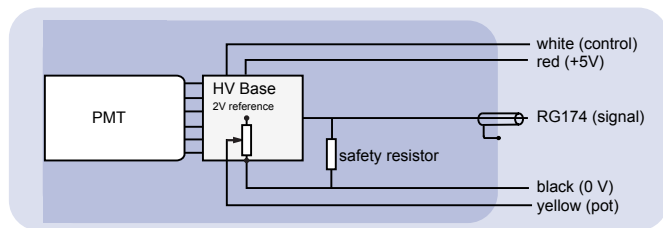

9 HV control options

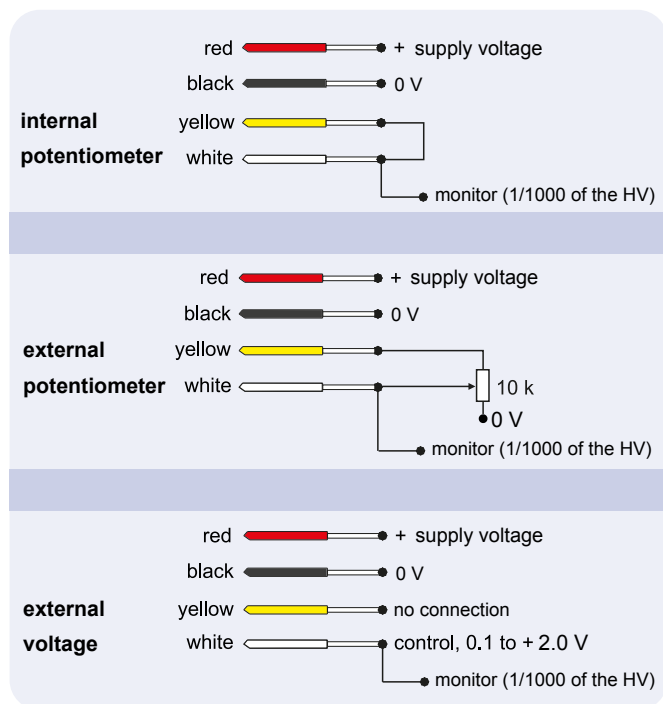

As supplied, the internal potentiometer is set to zero and should be rotated clockwise to increase the voltage when using this control option. When using an external potentiometer to control the HV, the internal potentiometer should be set to maximum (fully clockwise) to provide the correct 2V reference output on the yellow wire. The HV can be monitored by connecting a voltmeter between the white (control) and black (0 V) wires. The HV will be 1000 X the voltage on the white wire.

10 outline drawing mm

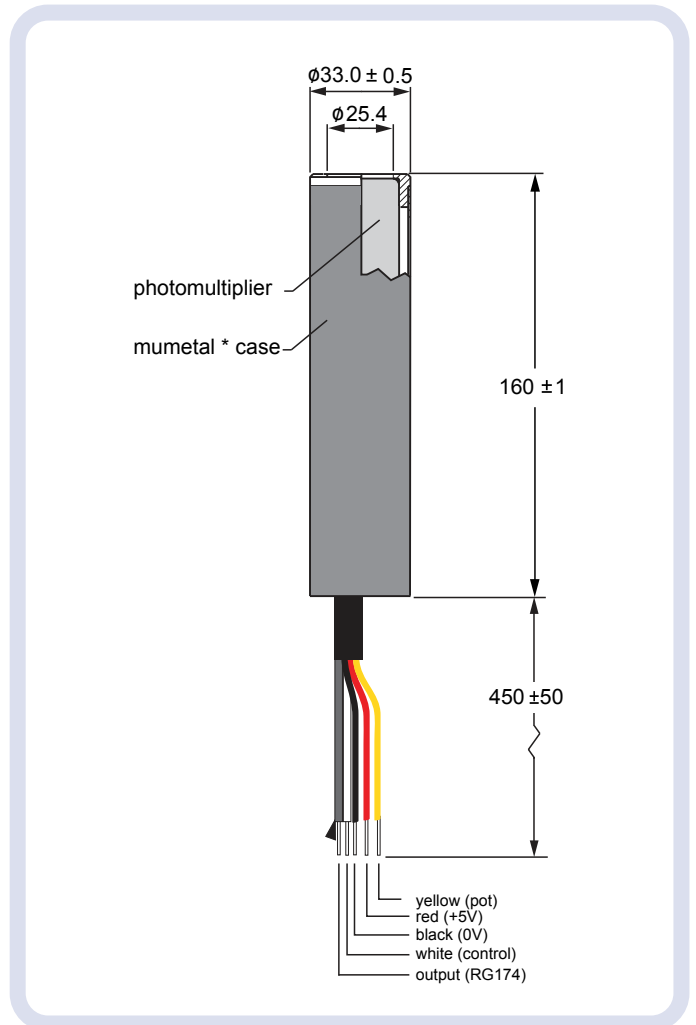

*mumetal is a registered trademark of Magnetic Shield Corporation

11 warning

The pmt cathode is operated at -HV. To guarantee stable performance and for safety reasons, the entire window should be isolated by a distance of at least 3 mm from any ground plane or components. The use of PTFE for insulation is recommended.

Do not expose the photocathode to strong light while the module is energised.

Operation beyond the maximum ratings, or reversal of the input voltage may result in loss of performance or permanent damage to the product.

Care should be taken not to exceed the maximum rated gain (2000A/lm) and/or operating voltage of the photomultiplier as specified on the accompanying test ticket and the 9125B data sheet.

*mumetal is a registered trademark of Magnetic Shield Corporation

ET Enterprises Limited
45 Riverside Way
Uxbridge UB8 2YF
United Kingdom
tel: +44 (0) 1895 200880
fax: +44 (0) 1895 270873
e-mail: sales@et-enterprises.com
web site: www.et-enterprises.com

ADIT Electron Tubes
300 Crane Street
Sweetwater TX 79556 USA
tel: (325) 235 1418
toll free: (800) 399 4557
fax: (325) 235 2872
e-mail: sales@electron tubes.com
web site: www.electrontubes.com

an ISO 9001 and ISO 14001 registered company

The company reserves the right to modify these designs and specifications without notice. Developmental devices are intended for evaluation and no obligation is assumed for future manufacture. While every effort is made to ensure accuracy of published information the company cannot be held responsible for errors or consequences arising therefrom.

ET Enterprises
electron tubes

© ET Enterprises Ltd, 2015
DS_PDM9125-CN Issue 1 (24/11/15)